

JEE Main – 2018 (CBT) Exam

Test Date: 15/04/2018

Test Time: 9:30 AM – 12:30 PM

Subject: JEE Main 2018 CBT EH

Physics

Q1:

A body of mass m is moving in a circular orbit of radius R about a planet of mass M . At some instant, it splits into two equal masses. The first mass moves in a circular orbit of radius $R/2$, and the other mass, in a circular orbit of radius $3R/2$. The difference between the final and initial total energies is

Options

1. $\frac{GMm}{2R}$

2. $-\frac{GMm}{2R}$

3. $-\frac{GMm}{6R}$

4. $+\frac{GMm}{6R}$

Q2:

In a screw gauge, 5 complete rotations of the screw cause it to move a linear distance of 0.25 cm. There are 100 circular scale divisions. The thickness of a wire measured by this screw gauge gives a reading of 4 main scale divisions and 30 circular scale divisions. Assuming negligible zero error, the thickness of the wire is:

Options

1. 0.4300 cm

2. 0.0430 cm

3. 0.2150 cm

4. 0.3150 cm

Q3:

The B-H curve for a ferromagnet is shown in the figure. The ferromagnet is placed inside a long solenoid with 1000 turns/cm. The current that should be passed in the solenoid to demagnetise the ferromagnet completely is:

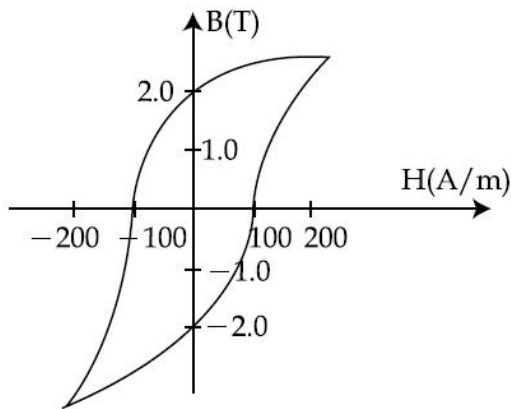

Options

1. 1 MA
2. 2.40 μ A
3. 20 μ A
4. 2 mA

Q4:

Two electrons are moving with non-relativistic speeds perpendicular to each other. If corresponding de Broglie wavelengths are λ_1 and λ_2 , their de Broglie wavelength in the frame of reference attached to their centre of mass is:

Options

1. $\lambda_{CM} = \lambda_1 = \lambda_2$
2. $\lambda_{CM} = \frac{2\lambda_1\lambda_2}{\sqrt{\lambda_1^2 + \lambda_2^2}}$
3. $\lambda_{CM} = \left(\frac{\lambda_1 + \lambda_2}{2}\right)$
4. $\frac{1}{\lambda_{CM}} = \frac{1}{\lambda_1} + \frac{1}{\lambda_2}$

Q5:

Light of wavelength 550 nm falls normally on a slit of width 22.0×10^{-5} cm. The angular position of the second minima from the central maximum will be (in radians):

Options

1. $\frac{\pi}{8}$
2. $\frac{\pi}{12}$
3. $\frac{\pi}{6}$
4. $\frac{\pi}{4}$

Q6:

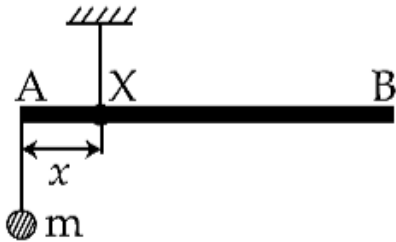

A uniform rod AB is suspended from a point X, at a variable distance x from A, as shown. To make the rod horizontal, a mass m is suspended from its end A. A set of (m, x) values is recorded. The appropriate variables that give a straight line, when plotted, are:

Options

1. $m, \frac{1}{x^2}$
2. m, x
3. $m, \frac{1}{x}$
4. m, x^2

Q7:

A Helmholtz coil has a pair of loops, each with N turns and radius R . They are placed coaxially at distance R and the same current I flows through the loops in the same direction. The magnitude of magnetic field at P , midway between the centres A and C , is given by [Refer to figure given below]:

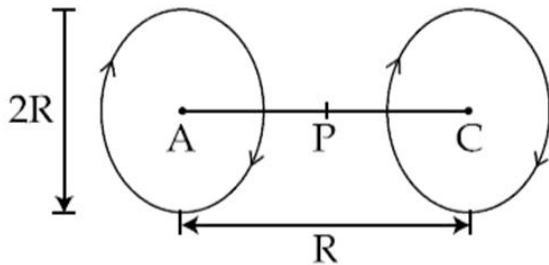

Options

1. $\frac{4N\mu_0 I}{5^{1/2}R}$
2. $\frac{8N\mu_0 I}{5^2 R}$
3. $\frac{4N\mu_0 I}{5^{3/2}R}$
4. $\frac{8N\mu_0 I}{5^{1/2}R}$

Q8:

An ideal capacitor of capacitance $0.2 \mu\text{F}$ is charged to a potential difference of 10 V . The charging battery is then disconnected. The capacitor is then connected to an ideal inductor of self-inductance 0.5 mH . The current at a time when the potential difference across the capacitor is 5 V , is:

Options

1. 0.34 A
2. 0.25 A
3. 0.15 A
4. 0.17 A

Q9:

Take the mean distance of the moon and the sun from the earth to be $0.4 \times 10^6 \text{ km}$ and $150 \times 10^6 \text{ km}$ respectively. Their masses are $8 \times 10^{22} \text{ kg}$ and $2 \times 10^{30} \text{ kg}$ respectively. The radius of the earth is 6400 km . Let ΔF_1 be the difference in the forces exerted by the moon at the nearest and farthest points on the earth and ΔF_2 be the difference in the force exerted by the sun at the nearest and farthest points on the earth.

Then, the number closest to $\frac{\Delta F_1}{\Delta F_2}$ is :

Options

1. 10^{-2}
2. 2
3. 6
4. 0.6

Q10:

An automobile, travelling at 40 km/h, can be stopped at a distance of 40 m by applying brakes. If the same automobile is travelling at 80 km/h, the minimum stopping distance, in metres, is (assume no skidding):

Options

1. 75 m
2. 160 m
3. 150 m
4. 100 m

Q11:

A charge Q is placed at a distance $a/2$ above the centre of the square surface of edge a as shown in the figure

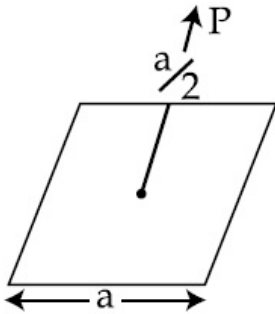

The electric flux through the square surface is:

Options

1. $\frac{Q}{6\epsilon_0}$
2. $\frac{Q}{\epsilon_0}$
3. $Q/3\epsilon_0$
4. $Q/2\epsilon_0$

Q12:

A force of 40 N acts on a point B at the end of an L-shaped object, as shown in the figure. The angle θ that will produce maximum moment of the force about point A is given by

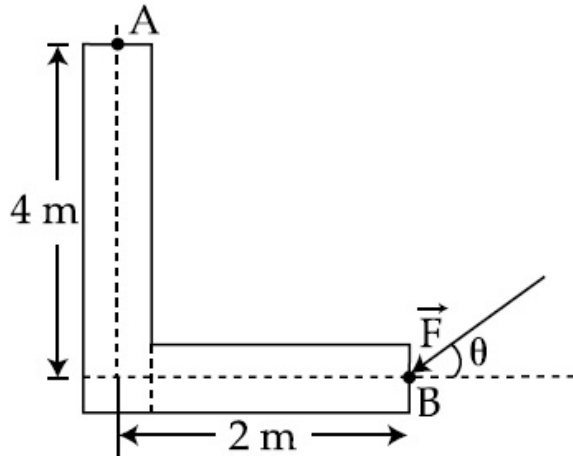
**Options**

1. $\tan\theta = \frac{1}{4}$
2. $\tan\theta = 2$
3. $\tan\theta = \frac{1}{2}$
4. $\tan\theta = 4$

Q13:

The equivalent capacitance between A and B in the circuit given below, is:

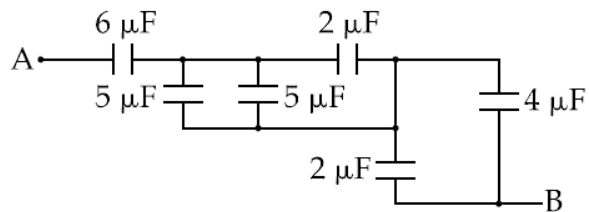
**Options**

1. $5.4\ \mu\text{F}$
2. $2.4\ \mu\text{F}$
3. $3.6\ \mu\text{F}$
4. $4.9\ \mu\text{F}$

Q14:

A monochromatic beam of light has a frequency $\nu = \frac{3}{2\pi} \times 10^{12}$ Hz and is propagating along the direction $\frac{\hat{i} + \hat{j}}{\sqrt{2}}$. It is polarized along the \hat{k} direction. The acceptable form for the magnetic field is:

$$\frac{E_0}{C} \hat{k}$$

Options

1. $\cos \left[10^4 \frac{(\hat{i} + \hat{j})}{\sqrt{2}} \cdot \vec{r} = +(3 \times 10^{12})t \right]$

$$\frac{E_0}{C} \frac{(\hat{i} - \hat{j})}{\sqrt{2}}$$

2. $\cos \left[10^4 \frac{(\hat{i} + \hat{j})}{\sqrt{2}} \cdot \vec{r} = -(3 \times 10^{12})t \right]$

$$\frac{E_0}{C} \frac{(\hat{i} - \hat{j})}{\sqrt{2}}$$

3. $\cos \left[10^4 \frac{(\hat{i} - \hat{j})}{\sqrt{2}} \cdot \vec{r} = -(3 \times 10^{12})t \right]$

$$\frac{E_0}{C} \frac{(\hat{i} + \hat{j} + \hat{k})}{\sqrt{3}}$$

4. $\cos \left[10^4 \frac{(\hat{i} + \hat{j})}{\sqrt{2}} \cdot \vec{r} = +(3 \times 10^{12})t \right]$

Q15:

A particle is oscillating on the X-axis with an amplitude 2 cm about the point $x_0 = 10$ cm, with a frequency ω . A concave mirror of focal length 5 cm is placed at the origin (see figure).

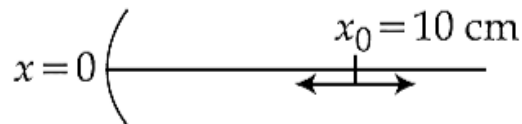

Identify the correct statements.

(A) The image executes periodic motion.

(B) The image executes non-periodic motion.

(C) The turning points of the image are asymmetric w.r.t. the image of the point at $x = 10$ cm.

(D) The distance between the turning points of the oscillation of the image is $\frac{100}{21}$ cm.

Options

1. (A), (D)

2. (A), (C), (D)

3. (B), (C)

4. (B), (D)

Q16:

A tuning fork vibrates with frequency 256 Hz and gives one beat per second with the third normal mode of vibration of an open pipe. What is the length of the pipe? (Speed of sound in air is 340 ms^{-1})

Options

1. 180 cm
2. 190 cm
3. 220 cm
4. 200 cm

Q17:

A thin uniform tube is bent into a circle of radius r in the vertical plane. Equal volumes of two immiscible liquids, whose densities are ρ_1 and ρ_2 ($\rho_1 > \rho_2$), fill half the circle. The angle θ between the radius vector passing through the common interface and the vertical is:

Options

1. $\theta = \tan^{-1} \frac{\pi}{2} \left(\frac{\rho_2}{\rho_1} \right)$
2. $\theta = \tan^{-1} \pi \left(\frac{\rho_1}{\rho_2} \right)$
3. $\theta = \tan^{-1} \left[\frac{\pi}{2} \left(\frac{\rho_1 - \rho_2}{\rho_1 + \rho_2} \right) \right]$
4. $\theta = \tan^{-1} \frac{\pi}{2} \left(\frac{\rho_1 + \rho_2}{\rho_1 - \rho_2} \right)$

Q18:

In a common emitter configuration with suitable bias, it is given that R_L is the load resistance and R_{BE} is small signal dynamic resistance (input side). Then, voltage gain, current gain and power gain are given, respectively, by:

β is current gain, I_B , I_C and I_E are respectively base, collector and emitter currents.

Options

1. $\beta^2 \frac{R_L}{R_{BE}}, \frac{\Delta I_C}{\Delta I_B}, \beta \frac{R_L}{R_{BE}}$
2. $\beta^2 \frac{R_L}{R_{BE}}, \frac{\Delta I_C}{\Delta I_E}, \beta \frac{R_L}{R_{BE}}$
3. $\beta \frac{R_L}{R_{BE}}, \frac{\Delta I_C}{\Delta I_B}, \beta^2 \frac{R_L}{R_{BE}}$
4. $\beta \frac{R_L}{R_{BE}}, \frac{\Delta I_E}{\Delta I_B}, \beta^2 \frac{R_L}{R_{BE}}$

Q19:

A given object takes n times more time to slide down a 45° rough inclined plane as it takes to slide down a perfectly smooth 45° incline. The coefficient of kinetic friction between the object and the incline is:

Options

1. $1 - \frac{1}{n^2}$
2. $\frac{1}{2-n^2}$
3. $\sqrt{\frac{1}{1-n^2}}$
4. $\sqrt{1 - \frac{1}{n^2}}$

Q20:

One mole of an ideal monatomic gas is compressed isothermally in a rigid vessel to double its pressure at room temperature, 27°C . The work done on the gas will be:

Options

1. $300 R \ln 7$
2. $300 R \ln 6$
3. $300 R \ln 2$
4. $300 R$

Q21:

A Carnot's engine works as a refrigerator between 250 K and 300 K . It receives 500 cal heat from the reservoir at the lower temperature. The amount of work done in each cycle to operate the refrigerator is:

Options

1. 772 J
2. 2520 J
3. 2100 J
4. 420 J

Q22:

In the given circuit all resistances are of value R ohm each. The equivalent resistance between A and B is:

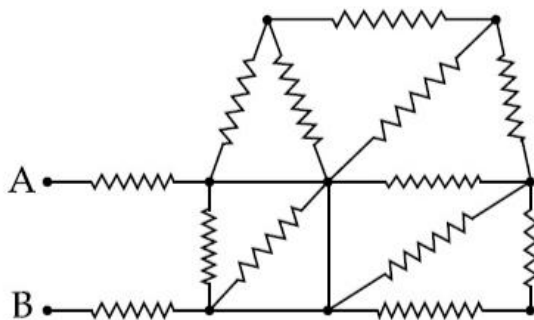
**Options**

1. $\frac{5R}{3}$
2. $3R$
3. $\frac{5R}{2}$
4. $2R$

Q23:

A solution containing active cobalt ${}_{27}^{60}\text{Co}$ having activity of $0.8 \mu\text{Ci}$ and decay constant λ is injected in an animal's body. If 1 cm^3 of blood is drawn from the animal's body after 10 hrs of injection, the activity found was 300 decays per minute. What is the volume of blood that is flowing in the body? ($1 \text{ Ci} = 3.7 \times 10^{10}$ decays per second and at $t = 10 \text{ hrs } e^{-\lambda t} = 0.84$)

Optional

1. 4liters
2. 5 liters
3. 6 liters
4. 7 liters

Q24:

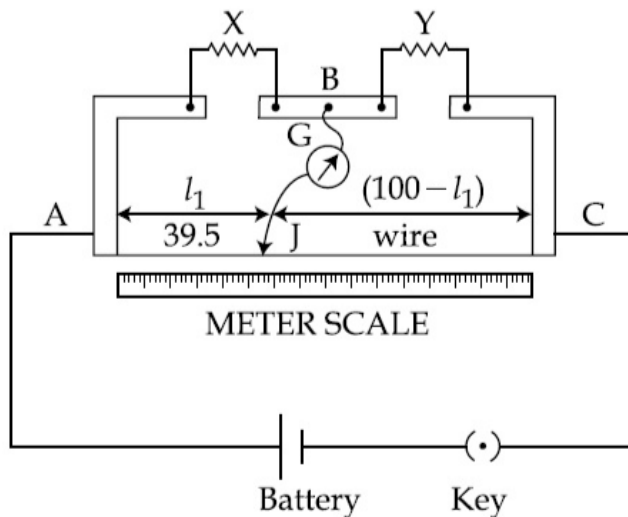

In a meter bridge, as shown in the figure, it is given that resistance $Y = 12.5 \Omega$ and that the balance is obtained at a distance 39.5 cm from end A (by Jockey J). After interchanging the resistances X and Y, a new balance point is found at a distance l_2 from end A. What are the values of X and l_2 ?

Options

1. 19.15Ω and 60.5 cm
2. 19.15Ω and 39.5 cm
3. 8.16Ω and 39.5 cm
4. 8.16Ω and 60.5 cm

Q25:

The energy required to remove the electron from a singly ionized Helium atom is 2.2 times the energy required to remove an electron from Helium atom. The total energy required to ionize the Helium atom completely is:

Options

1. 109 eV
2. 79 eV
3. 20 eV
4. 34 eV

Q26:

The number of amplitude modulated broadcast stations that can be accommodated in a 300 kHz band width for the highest modulating frequency 15 kHz will be:

Options

1. 10
2. 15
3. 20
4. 8

Q27:

The velocity-time graphs of a car and a scooter are shown in the figure. (i) The difference between the distance travelled by the car and the scooter in 15 s and (ii) the time at which the car will catch up with the scooter are, respectively.

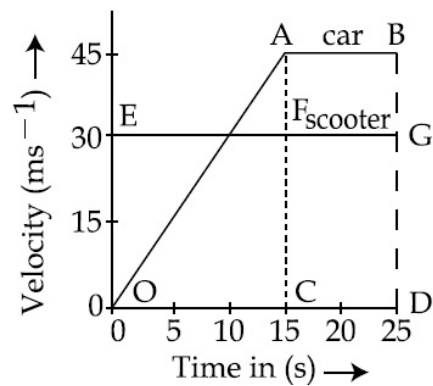

Options

1. 337.5 m and 25 s
2. 225.5 m and 10 s
3. 112.5 m and 15 s
4. 112.5 m and 22.5 s

Q28:

A body of mass M and charge q is connected to a spring of spring constant k . It is oscillating along x -direction about its equilibrium position, taken to be at $x = 0$, with an amplitude A . An electric field E is applied along the x -direction. Which of the following statements is correct?

Options

1. The new equilibrium position is at a distance $\frac{2qE}{K}$ from $x = 0$.
2. The new equilibrium position is at a distance $\frac{qE}{2K}$ from $x = 0$.
3. The total energy of the system is $\frac{1}{2}m\omega^2 A^2 - \frac{1}{2} \frac{q^2 E^2}{K}$
4. The total energy of the system is $\frac{1}{2}m\omega^2 A^2 + \frac{1}{2} \frac{q^2 E^2}{K}$

Q29:

A planoconvex lens becomes an optical system of 28 cm focal length when its plane surface is silvered and illuminated from left to right as shown in Fig-A.

If the same lens is instead silvered on the curved surface and illuminated from other side as in Fig. B, it acts like an optical system of focal length 10 cm. The refractive index of the material of lens is:

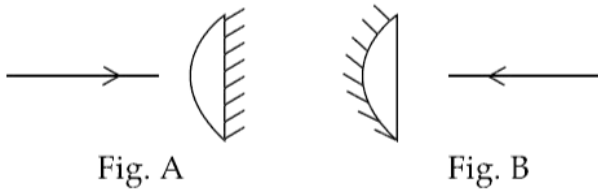
**Options**

1. 1.51
2. 1.75
3. 1.50
4. 1.55

Q30:

The relative error in the determination of the surface area of a sphere is α . Then the relative error in the determination of its volume is:

Options

1. $\frac{5}{2}\alpha$

2. $\frac{2}{3}\alpha$

3. α

4. $\frac{3}{2}\alpha$

Physics Solutions

Sol 1: (3)

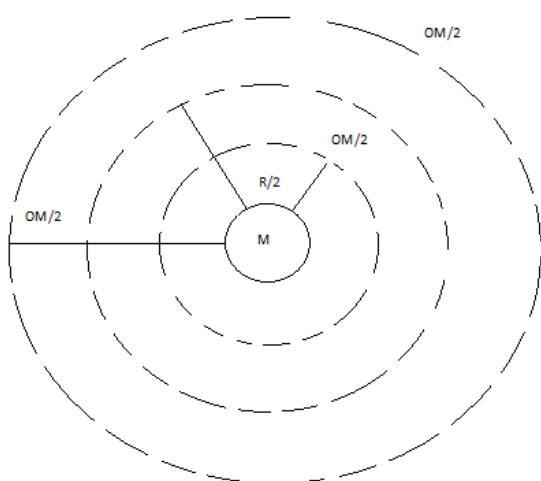

$$TE_i = \frac{GMm}{R} + \frac{1}{2} m \frac{Gm}{R} = \frac{-Gmm}{2R}$$

$$TE_F = \frac{Gm(m/2)}{R/2} - \frac{Gm\left(\frac{m}{2}\right)}{\frac{3R}{2}} + \frac{1}{2}\left(\frac{m}{2}\right) \frac{Gm}{\frac{R}{2}} + \frac{1}{2}\left(\frac{m}{2}\right) \frac{Gm}{3R/2}$$

$$= \frac{-4Gmm}{3R} + \frac{2Gmm}{3R}$$

$$TE_F = \frac{2Gmm}{3R}$$

$$TE_F - TE_i = \frac{-2Gmm}{3R} - \left(\frac{-Gmm}{2R}\right)$$

$$= \frac{-Gmm}{6R}$$

Sol 2: (3)

Given,

5 complete rotations of screw = 0.25cm

So 1 rotation of screw = 0.05

Hence, 1 main scale division = 0.05 cm

And 1 circular scale = $\frac{0.05}{100}$ division = 5×10^{-4} cm.

Now Reading is 4 main scale and 30 circular scale divisions

So, thickness = $4 \times 0.05 + 30 \times 5 \times 10^{-4}$

= 0.2150 cm.

Sol 3: (1)

From given diagram

Coercivity = -100 (A/m)

Hence

Reverse magnetic field required to demagnetize the substance

= $\mu_0 H$

= $\mu_0 100$

so $\mu_0 100 = \mu_0 N I$

$100 = \frac{1000}{10^{-2}} \times I$

$I = 1\text{m A}$

Sol 4: (3)

$$P_1 = \frac{h}{\lambda_1}, V_1 = \frac{h}{m\lambda_1}$$

$$P_2 = \frac{h}{\lambda_2}$$

$$v_2 = \frac{h}{m\lambda_2}$$

$$\vec{V}_{1c} = \vec{V}_1 - \vec{V}_{cm}$$

$$= v_1\hat{j} - \left(\frac{v_2\hat{i} + v_1\hat{j}}{2}\right)$$

$$\vec{V}_{1c} = \frac{v_1\hat{j} - v_2\hat{i}}{2}$$

$$\vec{V}_{2c} = \frac{v_2\hat{j} - v_1\hat{i}}{2}$$

$$|\vec{V}_{1c}| = |\vec{V}_{2c}| = \frac{1}{2} \sqrt{v_1^2 + v_2^2} = \frac{1}{2} = \frac{1}{2} \sqrt{\frac{h^2}{m^2\lambda_1^2} + \frac{h^2}{m^2\lambda_2^2}}$$

$$m|\vec{V}_{1c}| = \frac{1}{2} \sqrt{\frac{1}{\lambda_1^2} + \frac{1}{\lambda_2^2}}$$

$$\frac{1}{\lambda_{cm}} = \frac{\lambda_1^2 + \lambda_2^2}{2\lambda_1\lambda_2}$$

Sol 5: (3)

$$b \sin \theta = n\lambda$$

$$b \sin \theta = 2\lambda$$

$$\sin \theta = \frac{2 \times 550 \times 10^{-9}}{22 \times 10^{-7}} = 50 \times 10^{-2} = 0.5$$

$$\sin \theta = \frac{1}{2}$$

$$\theta = \pi/6$$

Sol 6: (3)

$$mgx = Mg\left(\frac{L}{2} - x\right)$$

$$m = \frac{ML}{2}\left(\frac{1}{x}\right) - M$$

$$= y = mx + c$$

Sol 7: (2)

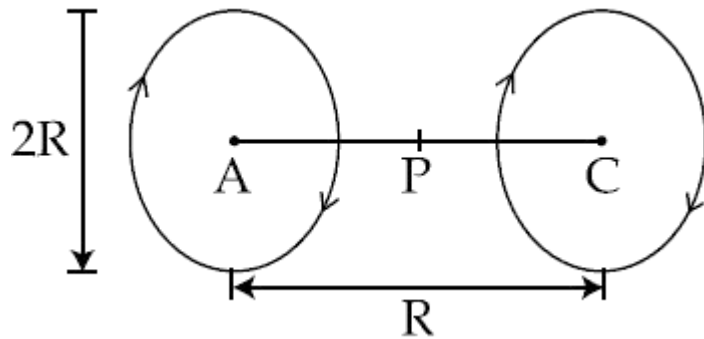

$$\vec{B} = \frac{\mu_0 i a^2}{2(a^2 + d^2)^{3/2}}$$

Here $d = \frac{R}{2}$ & $a = R$, N turns

$$\vec{B} = \frac{N\mu_0 i(R)^2}{2\left(R^2 + \frac{R^2}{4}\right)^{3/2}} = \frac{N\mu_0 iR^2}{2R^3 5^{3/2}} \times 8$$

$$\vec{B}_{\text{net}} = 2\vec{B} = \frac{8N\mu_0 i}{5^{3/2}R}$$

Sol 8: (4)

$$Q_o = 0.2 \times 10 \mu\text{C} = 2\mu\text{C}$$

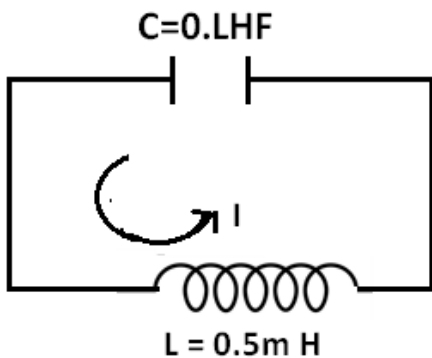

$$V_o = 10\text{V}$$

$$\text{Ei capacitor} = \frac{1}{2} \times 0.2 \mu\text{f} \times (10\text{v})^2$$

$$= 10\mu\text{J}$$

$$= \text{Ef capacitor} = \frac{1}{2} \times 0.2\mu \text{fx} (5\text{v})^2$$

$$= 2.5 \mu\text{j}$$

$$\Rightarrow \text{E inductor} = 7.5 \mu\text{J} = \frac{1}{2} Li^2$$

$$7.5 \times 10^{-6} = \frac{1}{2} \times 0.5 \times 10^{-3} \times i^2$$

$$30 \times 10^{-3} = i^2$$

$$i = \frac{\sqrt{3}}{10} = 017\text{A}$$

Sol 9: (2)

$$2 \times 10^{30} \text{kg} = m_2$$

$$8 \times 10^{22} \text{kg} = m_1$$

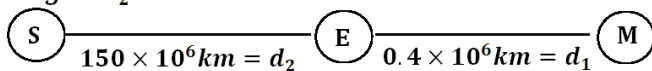

$$\Delta f_1 = \frac{GMm_1}{d_1^2} - \frac{GMm_1}{(d_1 + R)^2}$$

$$= GMm_1 \left[\frac{d_1^2 + 2d_1R + R^2 - d_1^2}{d_1^2(d_1 + R)^2} \right] \approx \frac{2d_1R}{d_1^2 d_1^2} = \frac{2R}{d_1^3} (GMm_1)$$

$$\Delta F_2 = \frac{GMm_2}{d_2^3}$$

$$\frac{\Delta F_1}{\Delta F_2} = \left(\frac{d_2}{d_1} \right)^3 \frac{m_1}{m_2}$$

$$= \left(\frac{150 \times 10^6}{0.4 \times 10^6} \right)^3 \left(\frac{8 \times 10^{22}}{2 \times 10^{30}} \right)$$

$$= (375)^3 (4 \times 10^{-8})$$

$$= (0.37 \times 10^3)^3 (4 \times 10^{-8})$$

$$= 1.64$$

Sol 10: (2)

$$u = 40 \frac{\text{Km}}{\text{hr}}$$

$$\mu = \frac{100}{9} \text{ m/s}$$

$$V^2 - u^2 = 2a \times 40$$

$$a = -1.54 \text{ m m/s}^2$$

Now.

$$-\left(\frac{80 \times 5}{18} \right)^2 = 2 \times (-1.54) \times 5$$

$$S = 160\text{m}$$

Sol 11: (1)

$$\text{Through whole cube} = \frac{Q}{\epsilon_0}$$

$$\text{Through one face} = \frac{Q}{6\epsilon_0}$$

Sol 12: (3)

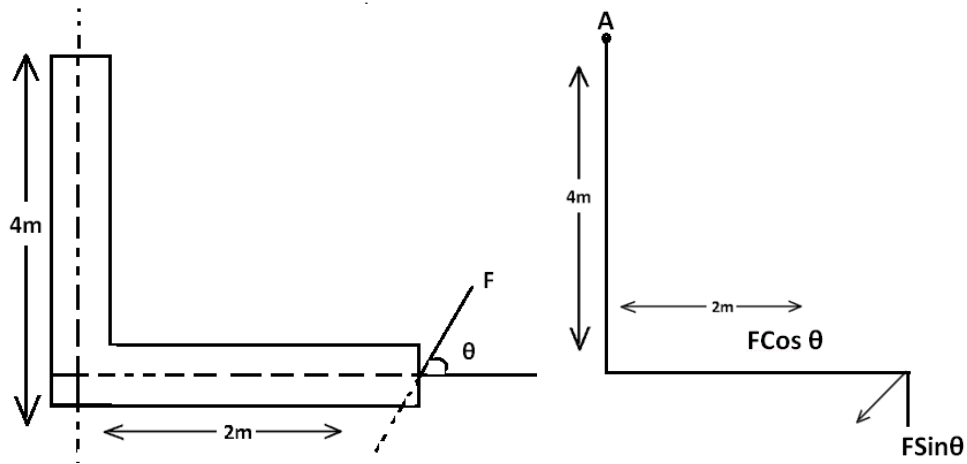

$$\tau_A = f \cos\theta(4) + F\sin\theta(2)$$

$$\tau_A = 2F(\sin\theta + 2\cos\theta)$$

$$\frac{d\tau_A}{d\theta} = 2F[\cos\theta - 2\sin\theta] = 0$$

$$\tan\theta = \frac{1}{2}$$

Sol 13: (2)

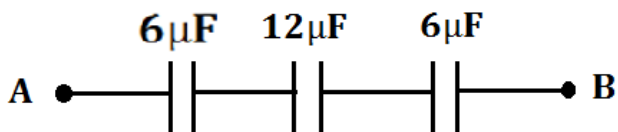

$$\frac{1}{C_{eq}} = \frac{1}{6} + \frac{1}{6} + \frac{1}{12} = \frac{2+2+1}{12} + \frac{5}{12}$$

$$C_{eq} = \frac{12}{5} \mu f = 2.4 \mu f$$

Sol 14: (2)

Direct formula base

Sol 15: (2)

When object is at 8 cm

$$V_1 = \frac{uf}{u-f} = \frac{-40}{3} \text{ cm.}$$

When object is at 12 cm.

$$V_2 = \frac{-60}{7} \text{ cm.}$$

so distance between images = $|V_2 - V_1|$

$$= \frac{100}{21} \text{ cm.}$$

Sol 16: (4)

Third normal mode of frequency in open pipe,

$$f = \frac{3V_s}{2l}$$

Where, $V_s = 340\text{m/s}$

Get $L = 2\text{m}$

Or

$L = 200 \text{ cm}$

Sol 17: (3)

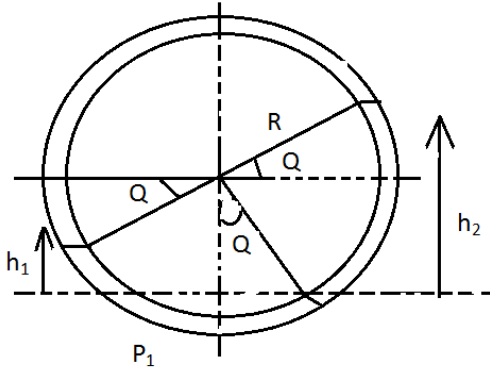

$$h_1 P_1 = h_2 P_2$$

$$(R \cos \theta + R \sin \theta) P_2 = (R \cos \theta - R \sin \theta) P_1$$

$$(P_1 + P_2) \sin \theta = (P_1 - P_2) \cos \theta$$

$$\tan \theta = \frac{P_1 - P_2}{P_1 + P_2}$$

Sol 18: (3)

Direct formula Based

Sol 19: (1)

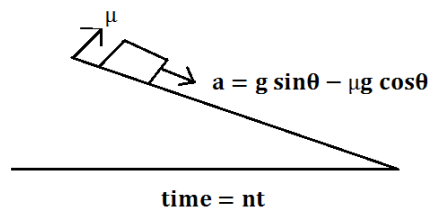
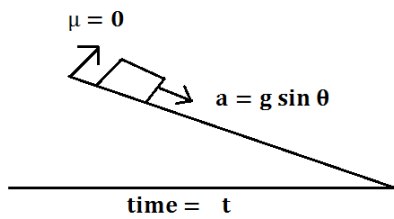

$$S = ut + \frac{1}{2} at^2$$

So

$$\frac{1}{2} g \sin \theta t^2 = \frac{1}{2} (g \sin \theta - \mu g \cos \theta) n^2 t^2$$

$$\sin \theta = n^2 \sin \theta - \mu n^2 \cos \theta$$

$$1 = n^2 - \mu n^2$$

$$1 - n^2 = -\mu n^2$$

$$n^2 - 1 = \mu n^2$$

$$\mu = 1 - \frac{1}{n^2}$$

Sol 20: (3)

$$\text{Work} = -nRT_1 \ln \frac{V_2}{V_1}$$

$$= nRT_1 \ln \frac{P_2}{P_1}$$

$$= 300R \ln 2$$

Sol 21: (4)

Given,

$$Q_2 = 500 \text{ cal.}$$

$$\eta_{\text{Carnot}} = 1 - \frac{T_2}{T_1}$$

$$= \frac{1}{6}$$

$$\text{and } (\text{COP})_{\text{HP}} = \frac{1}{\eta_{\text{Carnot}}} = 6$$

$$(\text{COP})_{\text{HP}} - (\text{COP})_{\text{Ref}} = 1$$

$$\text{So, } (\text{COP})_{\text{Ref}} = 5 = \frac{Q_2}{W}$$

$$\text{so } W = 100 \text{ cal}$$

$$\text{Or } W = 420 \text{ J}$$

Sol 23: (2)

$$\left(\frac{dn}{dt}\right) = -\lambda N_0$$

$$0.8 \mu \text{ Ci} = -\lambda N_0$$

$$N_1 = N_0(0.84)$$

$$v \rightarrow N_1$$

$$v \text{ cm}^3 \rightarrow \frac{N_1}{v}$$

$$\frac{N_1}{v} = \frac{N_0(0.84)}{v}$$

$$\lambda \left[\frac{0.84 N_0}{v} \right] = \frac{300}{60} \times \frac{1}{3.7 \times 10^{10}}$$

$$\frac{0.84 \times 0.8 \times 10^{-6}}{v} = \frac{5}{3.7 \times 10^{10}}$$

$$v = \frac{3.7}{5} \times 0.84 \times 0.84 \times 10^4 \text{ cm}^3$$

$$= 0.5 \times 10^4 \text{ cm}^3 = 5 \times 10^3 \text{ cm}^3 = 5 \text{ lit}$$

Sol 24: (4)

For balanced wheat stone bridge

$$x(100 - l_1) = y \times l_1$$

$$\text{So } x(100 - 39.5) = 12.5(39.5)$$

$$x = 8.16 \Omega$$

If x and y inter changed

$$y(100 - l_2) = x l_2$$

$$12.5(100 - l_2) = 8.16 l_2$$

$$\text{get } l_2 = 60.5 \text{ cm}$$

Sol 25: (3)

E_1 = ionization energy of ionized He

$$E_2 = 2.2E_1$$

$$E_1 = 13.6 \text{ eV}$$

$$E_2 = \frac{13.6}{2.2} = 6.18 \text{ eV}$$

$$\text{Total} = E_1 + E_2 = 13.6 \text{ eV} + 6.18 \text{ eV}$$

$$= 20 \text{ eV}$$

Sol 26: (1)

The station will require a band width of 30 kHz

So

$$\text{No. of stations} = \frac{300}{30}$$

$$= 10$$

Sol 27: (4)

$$a = \frac{45}{15} = \frac{9}{3} = 3 \text{ m/s}^2, \quad s_1 = u_1 t + \frac{1}{2} a_1 t^2$$

$$s_1 = \frac{1}{2} \times 3 \times (15)^2 = 1.5 \times 225$$

$$= 225 + 112.5$$

$$= 337.5 \text{ m}$$

$$s_2 = v_2 t$$

$$s_2 = 15 \times 30 = 450 \text{ m} \Rightarrow s_2 - s_1 = 112.5 \text{ m}$$

For catching up $\Rightarrow s_1 = s_2$

$$30t = \frac{1}{2} \times 3 \times t^2$$

$$20 = t$$

Sol 28: (4)

Energy at the extreme

$$= \frac{1}{2}kA^2 = T.E$$

After switching on electric field

New mean position $\Rightarrow kx_0 = qE$

$$x_0 = \frac{qE}{k}$$

So extreme position also shifts by $\frac{qE}{k}$

$$\Rightarrow T.E_{\text{new}} = \frac{1}{2}kA^2 + \frac{1}{2}k\left(\frac{qE}{k}\right)^2$$

$$= \frac{1}{2}mw^2A^2 + \frac{1}{2}\frac{q^2E^2}{k}$$

Sol 29: (4)

When plane surface is silvered

$$\text{Focal length } f_1 = \frac{R}{2(\mu - 1)} \dots (i)$$

$$\text{and } f_1 = 28 \text{ cm}$$

When curved surface is silvered

$$\text{Focal length } f_2 = \frac{R}{2\mu} \dots (ii)$$

$$\frac{f_1}{f_2} = \frac{R}{2(\mu - 1)} \times \frac{2\mu}{R}$$

$$2.8 = \frac{\mu}{\mu - 1}$$

$$\mu = 1.55$$

Sol 30: (4)

$$\text{Area of sphere (A)} = 4\pi R^2$$

taking log

$$\ln A = \ln(4\pi) + 2\ln(R)$$

differentiating both sides

$$\frac{dA}{A} = \frac{2}{R} \frac{dR}{R}$$

$$\text{so, } \alpha = \frac{2}{R} \frac{dR}{R}$$

$$\frac{dR}{R} = \frac{\alpha}{2}$$

now, similarly

$$\frac{dv}{v} = \frac{3}{R} \frac{dR}{R}$$

$$\text{So } \frac{dv}{v} = \frac{3\alpha}{2}$$

JEE Main: 2018 (Online CBT)

Answer Key (15/04/2018)

Part – A (Physics)

Q. No.	Answer	Q. No.	Answer	Q. No.	Answer
1	3	11	1	21	4
2	3	12	3	22	4
3	1	13	2	23	2
4	3	14	2	24	4
5	3	15	2	25	3
6	3	16	4	26	1
7	2	17	3	27	4
8	4	18	3	28	4
9	2	19	1	29	4
10	2	20	3	30	4